



# S360

ART00353



### FEATURES

- **Security level:**
  - Standard EN12320 Grade 4.
- **Body:**
  - Made of high performance steel alloy.
- **Shackle:**
  - Made of high performance steel alloy with high resistance to attacks and rust.
  - Diameter: 11mm.
  - Available in normal shackle and long shackle.
- **Opening / locking:**
  - Double locking system using steel ball bearings.
  - Cylinder with drill-resistant steel cotters and 7 pins in line.
- **Keys:**
  - 7 pin standard key.
  - Supplied with 3 keys.
- **Packaging:**
  - Blister packed.

### DIMENSIONS

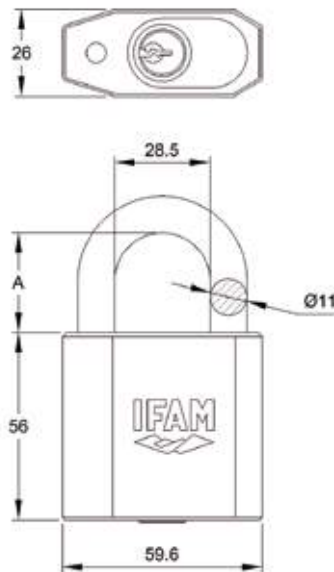

### SERVICES

- Master keying service
  - Keying alike service
  - Certain key number service
- 
- Laser engraving service

	S360	S360AL
A	30	50