

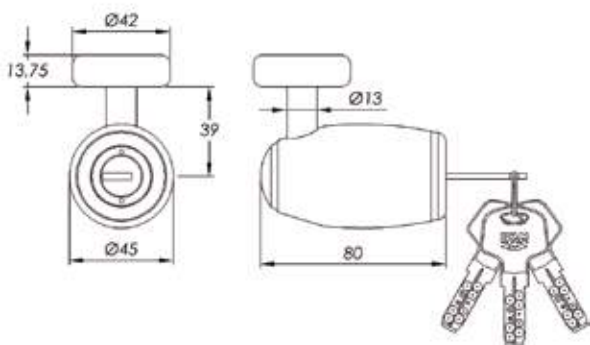

## SERVICES

- Unique key solution

## DIMENSIONS



## FEATURES

- **Body:**
  - Made of carbon nitride steel.
  - Covered by a special coat of paint for protecting the lock.
- **Cotter:**
  - Made of tempered and chromed steel..
  - Diameter: 13mm.
- **Opening / locking:**
  - Dimple key cylinder armoured with two hardened steel escutcheons.
- **Keys:**
  - Reversible dimple key with millions of differs.
  - Supplied with 3 keys.
  - Key compatible with: Titan, Hercules A /A Colour and Hercules B padlocks; Top Giant chain and Disk Giant 80 anti theft.
- **Packaging:**
  - In transparent plastic box.
  - Resistant fabric cover, Rec110 reminder cable and support bracket included.